

Falcon Cold Store

Cold Store Renting

Importer, Exporter & Distributor

Of all kind of Dry, Dairy, Chilled & Foodstuff Items



MSA 73164

TÜV SÜD TÜV SÜD TÜV SÜD TÜV SÜD TÜV SÜD TÜV SÜD TÜV SÜD TÜV SÜD TÜV SÜD TÜV SÜD TÜV SÜD TÜV SÜD TÜV SÜD TÜV SÜD TÜV SÜD

ZERTIFIKAT ◆ CERTIFICATE ◆ CERTIFICADO ◆ CERTIFICAT

إشهاد ◆ 證書 ◆ 證明書



CERTIFICATE

The Certification Body
of TÜV SÜD Middle East L.L.C.

certifies that



FALCON COLD STORE
P.O.Box 39959, Industrial Area No. 17
Sharjah, United Arab Emirates

has established and applies
a **HACCP System** for

**Receiving and Storage of
Packed Frozen and Dry Foodstuff**

An audit was performed, Report No. **50068**
Proof has been furnished that the requirements
according to

Codex Alimentarius Commission
are fulfilled.

The certificate is valid from **2017-10-30** until **2020-10-29**.
Certificate Registration No. **ME HACCP 0025 DAC**

Dubai, 2017-11-04



CB-021

TÜV

ZERTIFIKAT ◆ CERTIFICATE ◆ 認證證書 ◆ CERTIFICADO ◆ CERTIFICAT

MS01-47710



Management Service

CERTIFICATE

The Certification Body
of TÜV SÜD Management Service GmbH
certifies that



FALCON COLD STORE
P.O.Box 39959, Industrial Area No. 17
Sharjah
United Arab Emirates

has established and applies
a Quality Management System for

**Trading of
Packed Frozen and Dry Food Stuff Products
and Renting of Cold Stores.**

An audit was performed, Report No. **707040815**.
Proof has been furnished that the requirements
according to

ISO 9001:2015

are fulfilled.

The certificate is valid from **2018-03-05** until **2021-03-04**.

Certificate Registration No.: **12 100 49665 TMS**.



Product Compliance Management
Munich, 2018-02-28



TÜV SÜD Management Service GmbH • Zertifizierungsstelle • Ridlerstraße 65 • 80339 München • Germany

TUV®

About us

Falcon Cold Store introduces as one of the leading **Cold Store Renting & Importer Exporter & Distributer** of quality products mainly in Frozen Foods. We are backed with qualified & well experienced management with a wide industry experience of 30-years in Frozen Foodstuff distribution and having Fleets of more than 15 refrigerated vehicles across the UAE. We are also supported by fully motivated sales executives and experienced skilled team.

Falcon Cold Store has diversified in activities such as Frozen Foodstuffs, Cold Store Renting, which are directed mainly towards the areas of U.A.E. where the business activities are increasing rapidly.

These products offered by us are procured from certified manufacturers to ensure high quality standards. We have collaboration with the leading Vendors with whom we work in a close coordination to meet the specific demands of our clients.

The skilled team of our company works hard to provide maximum satisfaction to our clients. We import & distribute the products only after checking their quality standards with our ethical business strategies and transparent working policies, we have gained huge client base across the UAE. Due to our Quality range, Service & Pricing we have been successful in increasing our distribution day by day.

We have Cold Stores with different sizes & temperature from Chilled +4° to frozen -20°. All the goods kept separate like Mutton / Beef / Chicken / Sea Food / Vegetable & Dairy product with separate inventory.

Our Cold Stores is the first biggest cold store capacity in Sharjah and one of the biggest in U.A.E. to cater the need of storing facility.

Factors that make us the most preferred choice amongst our clients are:-

- ❖ Highly competitive price range
- ❖ Optimum quality products
- ❖ Transparency in business
- ❖ Well timed delivery
- ❖ Safe and secure cargo handling
- ❖ Wide distribution network

Our Main Frozen Products are:

- ❖ Poultry Cuts
- ❖ Beef Cuts
- ❖ Lamb & Mutton Cuts
- ❖ Sea Food
- ❖ Dairy products (Butter & Cheese)
- ❖ Vegetables & Fruits Pulps

Range of our products widely acclaimed for:

- ❖ High Quality
- ❖ Cost Effectiveness
- ❖ Reliability
- ❖ Premium Brands

Import, Export & Brand

Import From:

- ❖ USA, Argentina, Brazil, UK, Holland, Denmark, Belgium, Ukraine, Turkey, Oman, China, Vietnam, Taiwan, Thailand, India, Australia, New Zealand etc.

Points considered while dealing with vendors:

- ❖ Financial stability
- ❖ Timeliness
- ❖ Past clients served
- ❖ Consignment undertaking capacity

Export To:

- ❖ Oman, Kuwait, Qatar, Saudi.

Distribution Network in UAE:

- ❖ Star Hotels, Restaurants, Hyper Markets, A & B Class Super Markets, Catering Units, Traders, Ship chandlers, Butcheries etc covering all the areas across the UAE.

Major Brands we deal:

- ❖ Aurora, Tyson, Pena Branca, Cancao, Confidence, Frangosul, Borella, Avipal, Gloabaves, Quality, Globex, Fletcher, Midfield, Friboi, Minerva, Nowaco, Tomex, Geko, 5 Star, OK, Allana, Premier, Aseafood etc.

Product

Falcon Cold Store Deals only in "HALAL" Products as per UAE Islamic Law.

Our qualified & experienced management & adroit team members also makes sure that the products are sourced at market leading prices, that helps in maintain friendly relations with the clients. We also ensure the products are procured from certified vendors and are appreciated for its superb performance and high quality. We are having a fleet of refrigerated Pickups and vans which are approved and certified by the Food Control Department of U.A.E. for the distribution of foodstuff across the U.A.E.

Poultry Cuts



Beef Cuts



Lamb & Mutton Cuts



Dairy Products



Sea Food



Vegetables & Fruits Pulps



Dry Foodstuff



Quality

Quality Assurance – It is the policy of Sharjah Cold Store to operate under the principles of **HACCP (Hazard Analysis Critical Control Point)** ensure safety of food handling Which is free from physical, chemical and microbiological Contaminants, thereby reducing the risk of food poisoning or food borne infection.

As a front runner in the industry we strives to fulfill local and international food safety guidelines by adopting innovative and updated workable techniques. We ensure consistency of hygiene standards and food safety by properly laying the foundation of prerequisite programs which covers good hygiene practices.

In order to achieve the hygiene standards we are guided by Codex Alimentarius Guidelines, Sharjah Municipality-Food Control Section Guidelines and HACCP Guidance for Retail Premises 2011.

The Objectives Includes:

- Improve hygiene standard of handling food
- Reduce losses while handling food
- Increase customer satisfaction
- Impart training to all food handles

Infrastructure & Logistic

Infrastructure

Our primary Sharjah facility is located just 20 minutes from Dubai International Airport and 45 minutes from Jebel Ali port, with the overall cold store capacity 10,000 MT, 90,000 sq. ft. in Ind. area No. 17 which are located in Sharjah with latest technology.

Since we are the leaders in the tough competitive market, we have managed to provide modern facility for receiving and delivering with the laid back support of

our team. We maintain healthy and cordial relation with our clients and present them with an outstanding range. Our organization strives hard to fulfill all the Demands of the clients timely.

We have Cold Stores with different sizes & temperature from Chilled +4 degree to frozen -20 degree. All the goods kept separate like Mutton / Beef / Chicken / Sea Food / Vegetable & Dairy product with separate inventory. With the above mentioned factors, Falcon Cold Store have been able to cater to diversified clients.

Our Cold Stores features are:

- ✚ ISO 9001 – 2015 & HACCP Certified.
- ✚ 24 Hrs Technical Support.
- ✚ Regularly pesticide to avoid insects.
- ✚ The care and servicing by our seasoned technical personnel for the purpose of maintaining and facilities in satisfactory operating condition. It's achieved by performing systematic inspection, detection, and correction of incipient failures either before they occur or before they develop into major defects.

- ✚ Very spacious to enable maximum storage.
- ✚ Investigate & fix customer's complaints
- ✚ Provide regular maintenance facility.
- ✚ Online CC TV Monitoring
- ✚ Operational procedures in accordance with the law

Logistic

We are having fleet of 15 Refrigerated Vehicles which is cleaned , maintained and distributed through the various channels across the U.A.E. like 4&5Star Hotels, Restaurants, Hyper Markets, A & B Class Super Markets, Catering Units, Traders, Shipchandlers, Butcheries etc.

The products are stored in our spacious cold store which is equipped with all the Modern facilities. In our logistics, we have a quality control unit where the entire range being checked under the guidance of our quality controller.

Factors that make us the most preferred choice amongst our clients are:-

- ❖ Well timed delivery
- ❖ Safe and secure cargo handling
- ❖ Wide distribution network
- ❖ Optimum quality Vehicles
- ❖ Well trained staff

State-of-the-art warehousing and storage facilities combined with fast & effective distribution are the keys to the logistics operation at Falcon Cold Store.

Location Map:

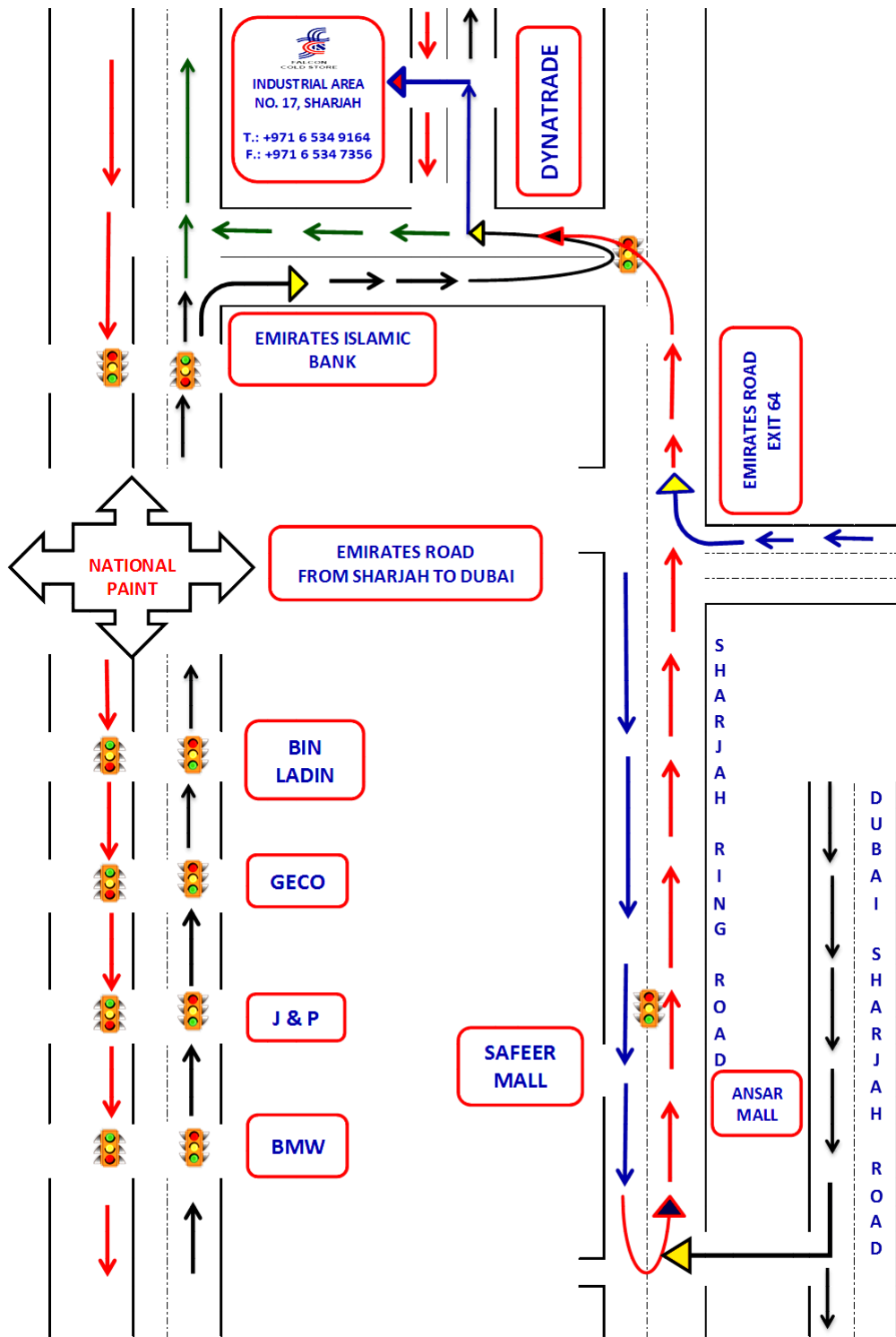

CONTACT US

Falcon Cold Store

P. O. Box 39959
Sharjah, UAE

For Cold Store Renting

Tel.: +971 6 5349164
Fax: +971 6 5349705
Email: fcs01@emirates.net.ae
info@falconcoldstore.com

For Food Stuff Trading

Tel.: +971 6 533 4748
Fax: +971 6 533 4728
Email: sales@falconcoldstore.com

For Further Information Refer to our web site www.falconcoldstore.com